

## VENTITEC® High-Volume Fans

Agricultural product for Light and Air



## Efficient air distribution by high-volume fans.



### VENTITEC® High-Volume Fans – Your cows will love them!

Our farm animals are not unlike people, in that a good working environment not only increases their well-being, but also their performance.

Optimal milking performance can only be ensured if your precious livestock are not under stress. Due to their metabolism, heat is the number one stress factor for cows given that they produce 20 to 60 MJ of thermal energy per day depending on performance. To avoid such stress in the long-term, fans have to be in continuous operation for a number of months throughout the summer.

The most energy-efficient method is provided by high-volume fans that ensure constant air circulation.

VENTITEC high-volume fans offer numerous benefits in that they:

- positively enhance the dairy barn climate
- prevent heat stress
- increase the productivity of your dairy cows
- are energy-efficient and save costs
- cool quietly



## How it works:

VENTITEC high-volume fans are able to move large volumes of air at low rotation speeds thanks to their large diameters.

They function in a similar way to state-of-the-art wind turbines. The tapered and twisted blades are optimised to fit the rotation speed. Air is sucked in from above the fan and pushed downwards and outwards in a broad cone. Fresh air from outside is consequently introduced into the circulation cycle and distributed throughout the dairy barn, thereby preventing accumulations of heat.

A pleasant breeze removes the warm and humid air mantle of noxious gases surrounding the livestock and has a cooling impact.

Due to the fact that VENTITEC high-volume fans do not need to periodically build up high speeds, they operate both quietly and efficiently.

Energy efficiency is an extremely significant factor on account of the long operating periods in the summer months (2,000–3,000 hours a year). The high-quality of the motors, gearboxes, hubs and blades all contribute to enhancing this efficiency. During winter, the rising warmth is slowly pushed back down and distributed evenly throughout the dairy barn.

Our VENTITEC high-volume fans are available in two diameters: 7.32 m and 4.88 m

- Air circulation within up to a 35 m radius (713.585 m<sup>3</sup>/h with the 7.32 m model)
- Lightweight, aerodynamically designed aluminium blades
- Extruded, precision-milled aluminium hubs and bolts
- Compliance with the highest safety standards
- Multiple fans regulated by intelligent control system
- Long life cycle
- No maintenance required

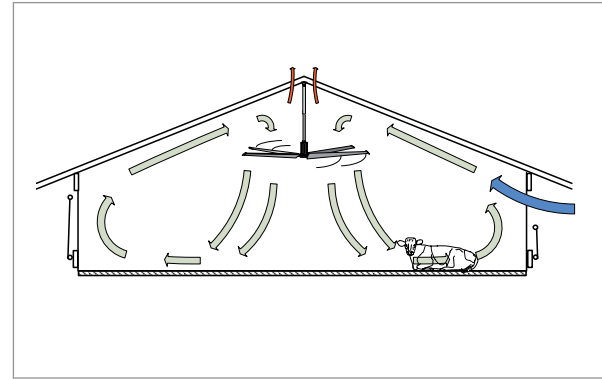

Balanced air quality through the introduction and circulation of fresh air

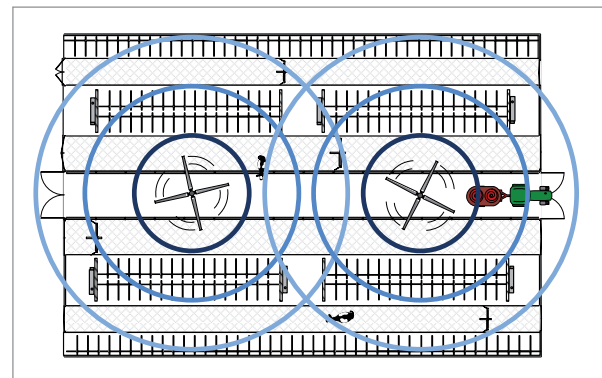

Our engineers and specialist retailers determine the optimal position to achieve the best possible ventilation

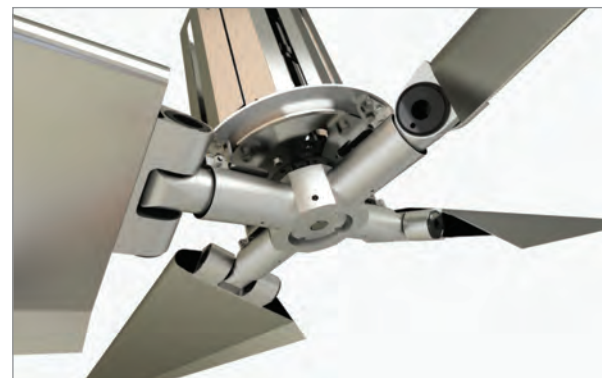

Vibration-absorbing construction based on 40 years of experience



## Components and installation measurements

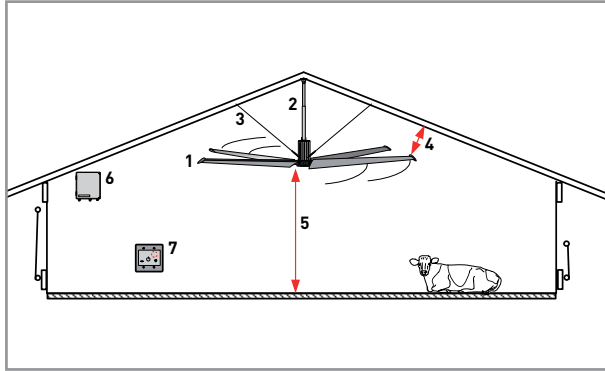

1. VENTITEC high-volume fans with 4 tapered rotor blades
2. Telescopic mounting drop
3. Diagonal guy lines
4. Minimum distance to ceiling construction (1.2 m and 1.5 m respectively)
5. Installation height (same as rotor diameter)
6. Frequency inverter in housing incorporating an EMC filter and choke coil
7. Manual control or automatic control using Eco-Commander as a centralised controller

### Technical Data:

#### VENTITEC® 4.88

|                      |                           |
|----------------------|---------------------------|
| Diameter:            | 4,88 m (16 ft)            |
| Volume of air moved: | 382.280 m <sup>3</sup> /h |
| Current:             | 3,55 Amp.                 |
| Supply:              | 400V ~3P 50 Hz            |
| Power consumption:   | 1,5 kW                    |
| Revolutions:         | 13-90 U/min               |
| Fan weight:          | 129 kg                    |

#### VENTITEC® 7.32

|                      |                           |
|----------------------|---------------------------|
| Diameter:            | 7,32 m (24 ft)            |
| Volume of air moved: | 713.585 m <sup>3</sup> /h |
| Current:             | 3,55 Amp.                 |
| Supply:              | 400V ~3P 50 Hz            |
| Power consumption:   | 1,5 kW                    |
| Revolutions:         | 9-60 U/min                |
| Fan weight:          | 136 kg                    |



## Control solutions:

The intelligent control systems are optimally coordinated with all the components to guarantee a smooth operation. Both manual and automatic control devices are available.



Manual operation of 1–4 fans. Settings: on/off, speed, rotation direction



Eco-Commander with touchscreen for automatic regulation according to temperature or timing program. Can control a maximum of 18 fans in 3 groups.

VENTITEC® high-volume fans are high-quality products from HUESKER's 'Light and Air' segment.

HUESKER offers a fully coordinated system for the optimum ventilation of your dairy barn in the form of LUBRATEC® side ventilation systems/wind protection solutions, SKYTEX® light ridge and VENTITEC® high-volume fans.

For further information go to [www.HUESKER.com](http://www.HUESKER.com)

Further Information:



**HUESKER Synthetic GmbH**

Fabrikstraße 13–15, 48712 Gescher  
Phone: + 49 (0) 25 42 / 701 - 0  
Fax: + 49 (0) 25 42 / 701 - 499  
E-Mail: [info@HUESKER.de](mailto:info@HUESKER.de)  
Internet: [www.HUESKER.com](http://www.HUESKER.com)

Standort Dülmen  
Im Brömken 5, D-48249 Dülmen  
Phone: +49 (0) 25 94 / 8 92 98 -0  
Fax: +49 (0) 25 94 / 8 92 98 -890  
E-Mail: [techtex@HUESKER.de](mailto:techtex@HUESKER.de)

 **HUESKER**  
Ideen. Ingenieure. Innovationen.